

- **MI44RF** 52-1/4"L x 45-3/4"D x 40-5/8"H
- **MI46RF** 75"L x 45-3/4"D x 40-5/8"H
- **MI48RF** 97-3/4"L x 45-3/4"D x 40-5/8"H

Included

- Breeze w/EnergyWise s/c refrigeration
- Adjustable wire rack deck
- Casters
- Corrosion resistant stainless steel tub & fan shroud
- Integrated average product temperature adjustable from 0°F to 40°F.
Low temp for frozen (excluding ice cream) (0°F), Medium temp for raw meat (38°F), Medium temp for produce/deli (40°F)
- One year parts & labor; 5 year compressor warranty
- Removable deck pans provide complete access to evaporator coil & refrigeration connections
- Straight insulated glass ends



MI46RF

Specify	Standard Features	Additional Options
EXTERIOR COLOR	• Painted (stock colors, specify RAL#)	• All other laminates • Laminate - Standard colors • Stainless steel (includes lower base)
INTERIOR COLOR	• Black	• Stainless steel
TRIM COLOR	• Black	• Electrical drop cord cover (matches exterior color) • Stainless steel (w/stainless ext. only)
BASE	• Black	• Stainless steel (w/stainless ext. only)
BUMPER	• 1" bumper, double strip (specify color)	
ELECTRICAL CONNECT	• 6' Straight blade power cord (self-cont.)	• 6' Locking power cord (self-cont.)
EVAPORATOR COIL	• Non-coated evaporator coil	• E-Coated evaporator coil
THERMOMETER	• Digital fahrenheit thermometer	• Digital celsius thermometer
MISCELLANEOUS		• Second year parts & labor warranty (excludes compressor)

Intended Environment: Type I - Designed to operate in ambient conditions of 75°F with 55% relative humidity unless noted otherwise in system information below.		
Zone	Intended Product To Be Displayed	Warmest Avg Prod Temp ° F
1	Packaged frozen (0°) Packaged raw meat (38°) Packaged produce/deli (40°)	0-38-40

PLAN VIEW

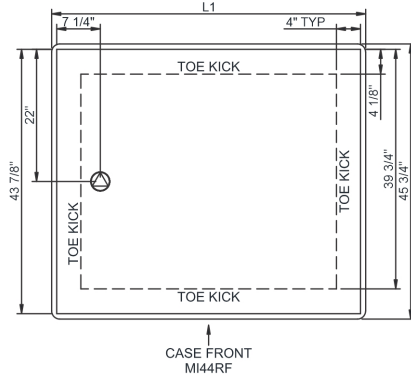

SIDE VIEW

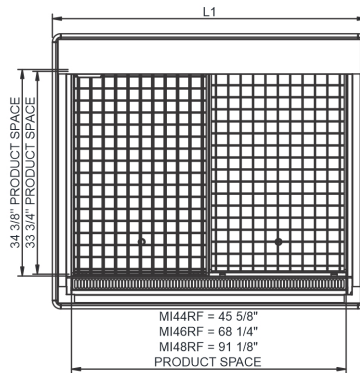
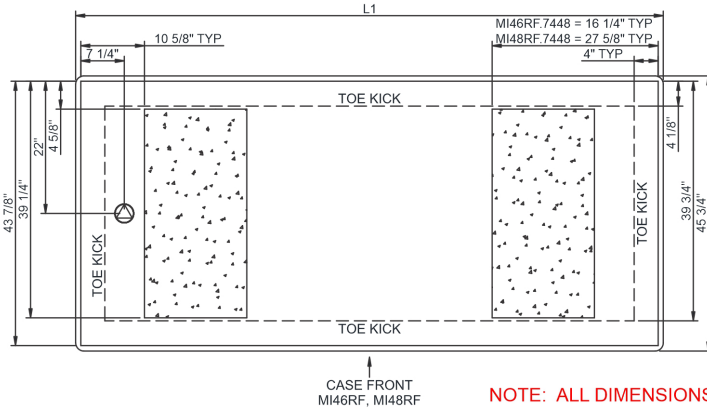
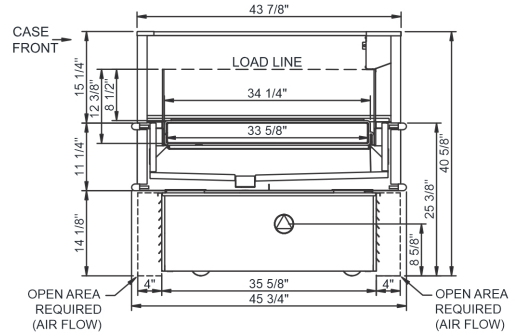

NOTE: ALL DIMENSIONS APPROXIMATE

- ELECTRICAL JUNCTION BOX**
(SUPPLIED WITH 6" LEADS OR POWER CORD).
- LOCATION OF DRAIN TUBE FOR REMOTE REF.**
ONLY (SUPPLIED WITH 3/4" OR 1 1/2" PVC TUBE).

- REFRIGERATION LINE CONNECTION.**
- REMOTE FLOOR SINK & UTILITIES ACCESS AREA.**

- SELF-CONTAINED CASE SERVICE ACCESS AREA.**
- DRY CASE SERVICE ACCESS AREA.**

Model Technical Specifications

Model	L"	L1"	L2"	System Circuit Volts	Phs	Freq	Amps ***	Watts	Wires	NEMA Plug	SST	Conv. Rack BTUH	Para. Rack BTUH	Est Wt		
M144RF	N/A	52.25	.00	Self-Contained (R449A)	Circuit #1	208-240	1	60	15.90	2,326	2+G	6-20P or L6-20P	N/A	N/A	N/A	900
M146RF	N/A	75.00	.00	Self-Contained (R449A)	Circuit #1	208-240	1	60	15.69	2,418	2+G	6-20P or L6-20P	N/A	N/A	N/A	1,150
M148RF	N/A	97.75	.00	Self-Contained (R449A)	Circuit #1	208-240	1	60	18.13	2,524	2+G	6-30P or L6-30P	N/A	N/A	N/A	1,500

*** Does not include electric defrost on freezer models.

Regulatory Approvals:

All Models
 Accordance with AHRI Std 1200
 ETL Listed to UL 471
 ETL Listed to CAN/CSA 22.2 No. 120
 ETL Sanitation to NSF/ANSI 7



In Accordance with
AHRI Std 1200

DOE 2017
Energy Efficiency
Compliant

Important Notes:

- 1) ELECTRICAL NOTE: If GFCI is required, a GFCI breaker MUST be used in lieu of a GFCI receptacle
- 2) Maximum load height is 8-1/4" up from deck.
- 3) Compressor air side intake and side discharge. All louvered panels cannot be blocked

⚠ WARNING: This product can expose you to chemicals, including Urethane (Ethyl Carbamate), which are known to the State of California to cause cancer and birth defects or other reproductive harm. For more information go to www.P65Warnings.ca.gov.

Note: Information is subject to change at any time. Visit www.structuralconcepts.com for the most current specs.

21868427

Revised 10-17-2022